

ASK IF ANY DOUBT

DRG.NO :-AS-DR-11663

No of Teeth	03
Point Angle	-/-
CuttingDirection	RH
Flute	Straight
Coolant	Internal
Coating	-/-

Component Detail

Project Name	-/-
Component Name:	-/-
Operation	-/-
Working Depth	-/-
Component Matl	-/-
Material Hardness	-/-

Cutting Parameters

Cutting Speed	-/-
Feed	-/-

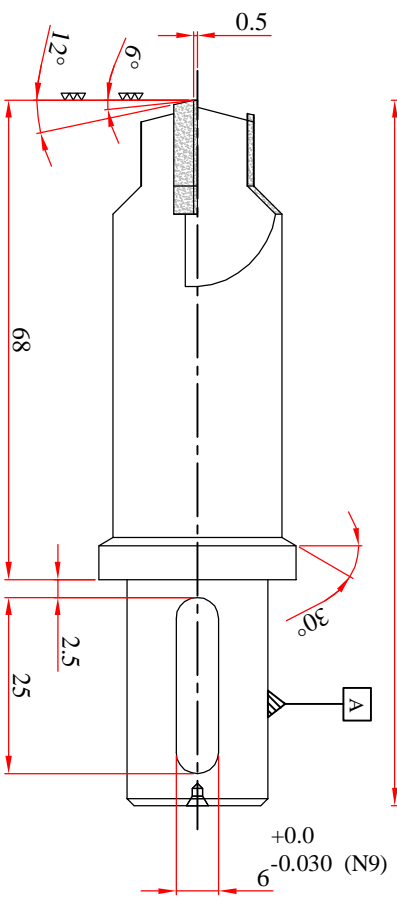
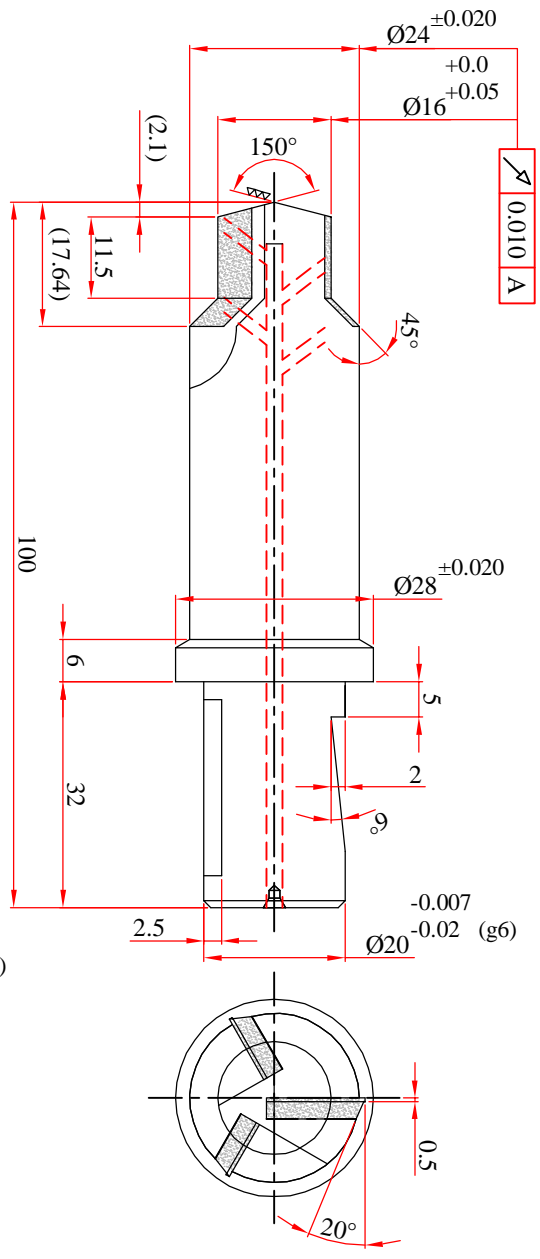

NOTES:-

- *. No Coating permitted on shank.
- *. Flute runover should be gradual & smooth.

ACCU SHARP CUTTING TOOLS PVT. LTD
 W -242, J Block, MIDC Bhosari, Pune 411 026.
 Gen Tol as Per IS 2102 (Part)-1980 (Medium)

Description:-
 AS-DR-11663 C.T TCH BRAZED PROFILE
 TOOL Ø 16 X Ø 24 X Ø 28 X 100 OAL X 20
 SH_U967

0.5-6	6-30	30-120	120-315	1000-2000
±0.1	±0.2	±0.3	±0.5	±0.8

Scale:	ALL DIMENSION IN MM
NTS	
Drawn	Siddalingk
Checked	1-2-Jul-14
Approved	
Customer Drg.No:-	
Customer Code :-	C0519
DRG.NO :-AS-DR-11663	